



Macadams 480 Rotary Rack Oven



FEATURES & BENEFITS

- Two stage heat control 4 rack capacity
- Simple control panel.
- Electrical or fuel execution
- High grade stainless steel design
- Robust design



M480 Rack Oven	
Power Rating (kW)	Electrical : 160 Fuel : 214 (burner) 7 Electrical
Supply Voltage	230 / 400 V, 50 Hz 3 phase, neutral & earth. Other voltages available on request.
Control Voltage (V)	230
Current Rating at 400 V	Electrical : 240 A Fuel : 11 A
Baking Surface (m²)	25.1
Product: Standard Bread: 600 - 900 g Rolls: 60 g (6 x 4 / tray) Baguettes: 500 g (5 fluted trays) Pies (foil): 100 g (6 x 4 / tray)	Capacity 480 144 dozen 360 144 dozen
Capacity (mm)	18 x 4 x (457 x 762)
Weight (kg)	Electrical : 4120 Fuel : 4610

Oven dimensions in mm: exclude all protrusions (door handles, drain exits etc).
Allow an additional 200mm for protrusions

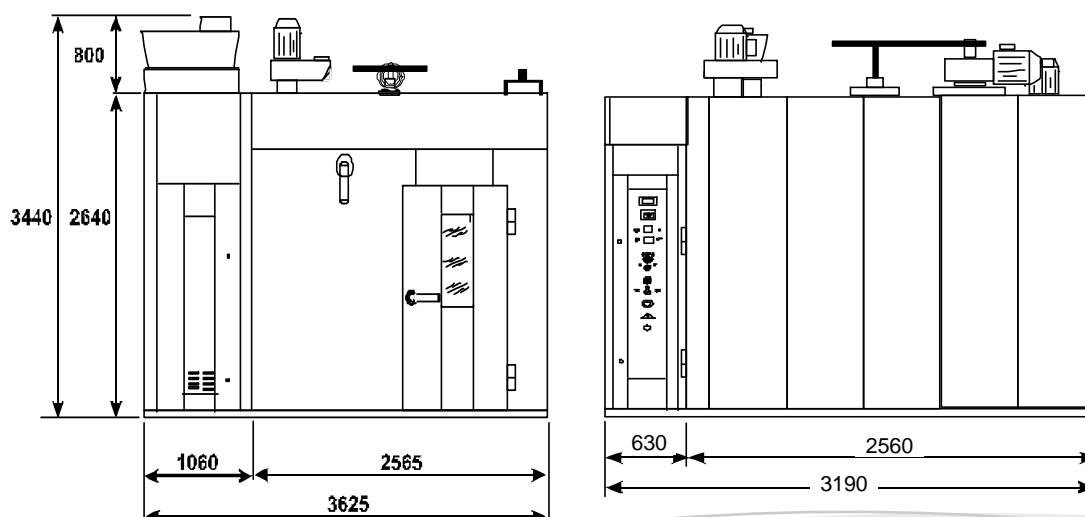

Contact Details

HEAD OFFICE, EXPORTS & CAPE TOWN BRANCH Tel : +27 (21) 907-1000 Fax : +27 (21) 907-1111

JOHANNESBURG BRANCH Tel : (011) 472-4100 Fax : 086 618 6462

DURBAN BRANCH Tel : (031) 569-6290 Fax : (031) 569-6296

EMAIL info@macadams.co.za

WEBSITE www.macadams.co.za